

Marek Szczerbiński

PRINCIPLES OF THE ELECTRIC INSULATION DESIGN BASED
ON THE RELIABILITY THEORY

1. Introduction

The scope of this paper is to present the principles of the insulation design methodology which leads to the best reliability characteristic under existing conditions. If we plan that the insulation will be exploited till the natural destruction, we have an interest in the expected value of the life-time $E\{T\}$. Among all possibilities such design is choosed which gives the maximum value $E\{T\}$.

On the other hand, we not seldom plan the preventive replacement after the limited work period t_0 . In such case we have an interest in the reliability function $R(t)$. Now, among all possibilities we choose the insulation system which leads to the maximum value $R(t_0)$.

In compliance with the reliability theory, the expected value of the life-time may be presented with the following formula [1]:

$$E\{T\} = \int_0^{\infty} R(t) dt \quad (1)$$

whereas

$$R(t) = \exp \left[- \int_0^t \lambda(\tau) d\tau \right] \quad (2)$$

The hazard function $\lambda(t)$ is defined as follows:

$$\lambda(t) = \lim_{\Delta t \rightarrow 0} \frac{P(t < T \leq t + \Delta t | T > t)}{\Delta t} \quad (3)$$

where: T - life-time of the object,

$P(t < T \leq t + \Delta t \mid T > t)$ - the conditional probability that the object, efficient till t moment, will be destructed during the period $(t, t + \Delta t]$

The reliability function $R(t)$ is the probability that the object working under the specified conditions ψ fulfills all requirements of efficiency ω at the moment t :

$$R(t) = P(T > t; \omega, \psi) \quad (4)$$

With regard to the foregoing considerations let us define the working conditions and the duties of the electric insulation as an object of the reliability theory. Of course, its fundamental job is to limit the current between the elements of various potentials. The limit current value results from the techno-economic characteristics of the object or system under consideration. Usually, the choose of the limit leakage current value is more or less arbitrary. However, the breakdown of electric insulation is, as a rule, a catastrophic process. Consequently, the breakdown current increases from the evidently accepted value to the evidently unaccepted one during a very short period t , that the arbitrary choice any moment in the range of this period has no influence on the reliability characteristics.

The electric insulation may do some additional jobs, for example it sometimes works as a supporting structure or as a cooling medium. However, the following analysis is concerned exclusively on the fundamental-insulation duty. So, the requirements will be reduced to the demand that the leakage current has to be below a certain critical value.

Sometimes, the destruction of the electric insulation occurs by the other way: for example the insulation may be broken, displaced, flown out etc. However, the following analysis will be limited to the breakdown phenomenon. It occurs when the electric field value exceeds the electric strength of the insulation. (Of course, the electric strength may decrease versus time as a result of the ageing phenomena).

So, from the standpoint of working conditions, we have an interest in the working voltage and overvoltages influencing the insulation. The full set of parameters consists of the working voltage value U_{work} , the over-

voltage frequency n and the probability density function of the overvoltages $d(U_{ov})$. We assume, that the overvoltage series is the Poisson's type process and the electric strength characteristics of the insulation $E_p(t)$ are univocally determined.

2. Principles of the homogeneous insulation choose

The electrode system and n dielectric materials defined with the electric strength characteristics $E_{b1}(t), E_{b2}(t), \dots, E_{bn}(t) \dots E_{bn}(t)$ are given. The problem is to choose such dielectric material from this set which working as a homogeneous insulation leads to the maximum value $E\{T\}$ or, in the other case, to the maximum value $R(t_0)$.

If the voltage between the electrodes $U_{work} = \text{const}$ (without any overvoltages) the solution of the problem is self-evident (see Fig.1). The life-time of each dielectric material T and the reliability function $R(t)$ are univocally determined: so, in this case, the idea of $E\{T\}$ is needless.

On the other hand, if the overvoltages are present, the design analysis is as follows: One must determine the probability density function for the maximum electric field created with overvoltages in the interior of the insulation. This function has the same shape as the probability density function of the overvoltages $d(U_{ov})$ but

$$E_{ov \max} = \frac{U_{ov}}{f(\text{electrode geometry})}$$

where: $E_{ov \max}$ - electric field created with overvoltages in this point inside the insulation where it reaches maximum value (field heterogeneity inside the homogeneous dielectric results from the electrode curvature),

$f(\text{electrode geometry})$ - factor of proportionality between the voltage on the electrodes and the maximum electric field inside the dielectric,

Next, the designer determines (for each dielectric separately) the time characteristic of these overvoltages which destruct the insulation. The frequency of the destructive overvoltages $n_{destruct}(t)$ is connected with the frequency of all overvoltages $n(t)$ by means of the following formula:

$$n_{\text{destruct}}(t) = \lambda(t) = n \int_{E_b(t)}^{\infty} d(E_{\text{ov max}}) dE \quad (5)$$

For $t = t_1$ (where t_1 is the solution of the equation $E_b(t) = E_{\text{work}}$) the hazard function $\lambda(t) \rightarrow \infty$

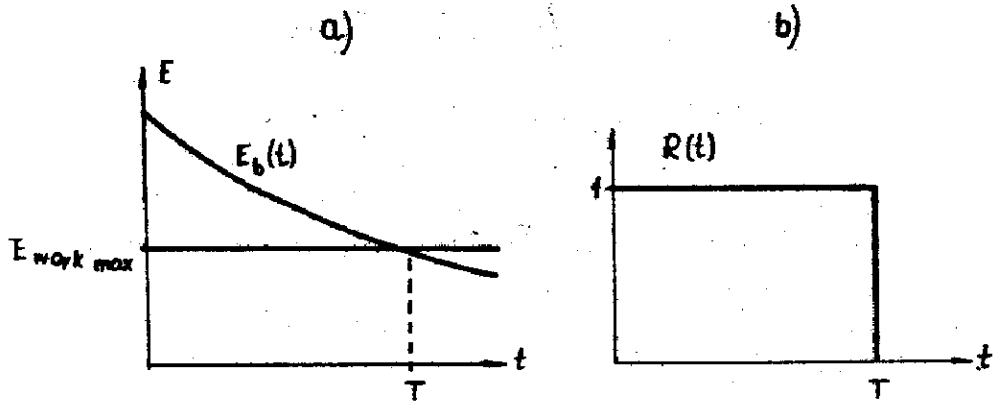

Fig.1. Life-time determination (a) and the probability function (b) for the homogeneous electric insulation

$$(E_{\text{work max}} = \frac{U_{\text{work}}}{r(\text{electrode geometry})})$$

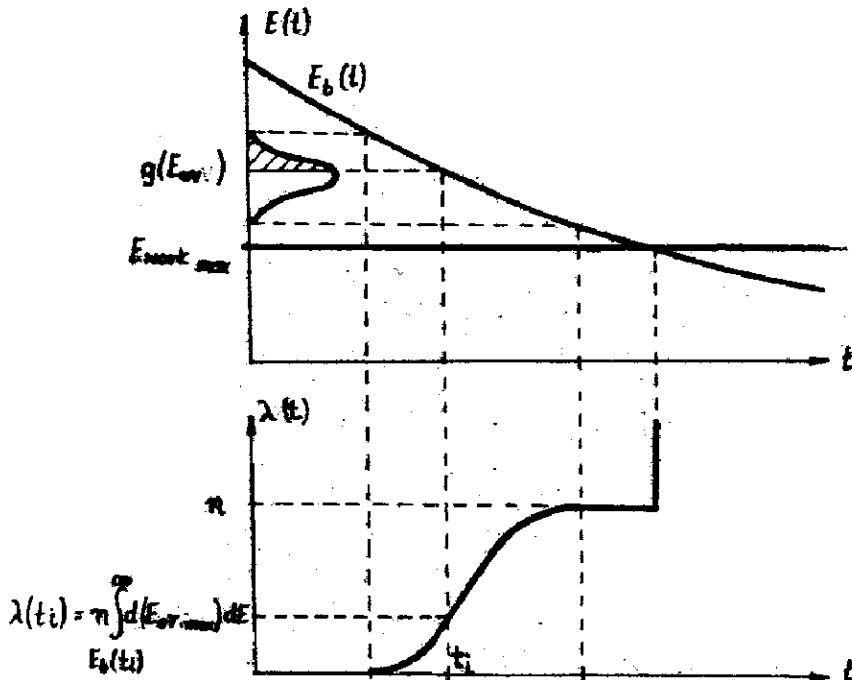

Fig.2. Determination of the hazard function $\lambda(t)$ for the homogeneous electric insulation influenced with working voltage and overvoltages

On the basis of $\lambda(t)$ function and the formulae (1), (2), (3), the designer may determine $E\{T\}$ and $R(t_0)$ values and choose the dielectric material of maximum value $E\{T\}$ or $R(t_0)$.

3. Principles of the multilayer insulation design

The design methodics will be presented for the case of 2 layer insulation system between coaxial cylinder electrodes (see Fig.3). Two dielectric materials of known characteristics $E_{b1}(t)$ and $E_{b2}(t)$ are given: the problem is to construct the insulation system which leads to the maximum value $E\{T\}$ or $R(t_0)$.

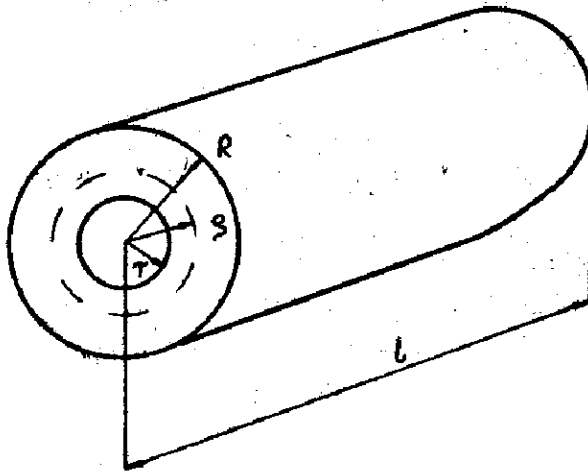

Fig.3. Two - layers electric insulation for coaxial cylinder electrodes

If the voltage between the electrodes $U_{\text{work}} = \text{const}$ (without any over-voltages) the beginning of the analysis is close to the typical case when $E_{b1}(t)$ and $E_{b2}(t)$ are constant [2]. The maximum electric field values inside the insulation layers are

$$E_{1 \text{ max}} = \frac{Q}{2\pi l \epsilon_1 r}, \quad E_{2 \text{ max}} = \frac{Q}{2\pi l \epsilon_2 s}$$

To have the maximum life-time value of the insulation system one must choose such radius r that

$$\frac{E_{b1}(t)}{E_{b2}(t)} = \frac{E_{1 \max}}{E_{2 \max}} = \frac{\varepsilon_2 \rho}{\varepsilon_1 r} \quad (6)$$

thus

$$\rho = r \frac{\varepsilon_1 E_{b1}(t)}{\varepsilon_2 E_{b2}(t)} \quad (7)$$

The breakdown occurs at the moment when $E_{b1}(t)$ function diminishes to the $E_{1 \max}$ value (of course, at this moment, $E_{b2}(t) = E_{2 \max}$ too). So, the life-time of the insulation system may be determined by means of the following formula

$$E_{b1}(t) = E_{1 \max} = \frac{\varepsilon_2 U_{\text{work}}}{r(\varepsilon_1 \ln \frac{R}{\rho} + \varepsilon_2 \ln \frac{\rho}{R})} \quad (8)$$

Solving the equations (7) and (8) one may determine the radius for the maximum life-time of the insulation system and the value of its maximum life-time $t = T_{\max}$.

The above analysis is valid on condition that $E_{b1}(t)$ and $E_{b2}(t)$ are monotonic functions. This is true because of irreversibility of the ageing processes.

Now, let us consider the case of the overvoltages characterized by the frequency n and the probability density function $d(U_{\text{ov}})$. The insulation system may be destructed by means of the overvoltages before the E_{b1} function will diminish to the $E_{1 \max}$ value.

If the ratio

$$\frac{E_{2 \max}}{E_{1 \max}} = \frac{\varepsilon_1 r}{\varepsilon_2 \rho} = k \quad (9)$$

then, in accordance with Fig.4., the electric strength of the insulation system is determined by means of $E_{b1}(t)$ for the period $(0, t_0)$ and with $E_{b2}(t)$ for $t > t_0$.

So, the hazard function $\lambda(t)$ may be determined individually for 3 time periods as follows:

1). for $0 \leq t \leq t_0$

$$\lambda(t) = \lambda_1(t) = n_{\text{destruct}} = n \int_{E_{b1}(t)}^{\infty} \frac{d(U_{\text{ov}})}{r(\varepsilon_1 \ln \frac{R}{\rho} + \varepsilon_2 \ln \frac{\rho}{R})} dS \quad (10)$$

2). for $t_0 \leq t \leq t_1$

$$\lambda(t) = \lambda_2(t) = n_{\text{destruct}} = n \int_{E_{b2}(t)}^{\infty} \frac{d(U_{ov})}{\varphi (\varepsilon_1 \ln \frac{R}{\varphi} + \varepsilon_2 \ln \frac{\varphi}{R})} dE \quad (11)$$

3). and for $t > t_1$

$$\lambda(t) = \lambda_3(t) \rightarrow \infty \quad (12)$$

Now, let us determine the radius φ which gives the maximum value of the reliability function $R(t_e)$. Using the equations (2), (10) and (11), taking into considerations that t_1 results from the (6), we receive the following formula

$$R(t) = \exp - \left[\int_0^{t_0} \lambda_1(\tau) d\tau + \int_{t_0}^t \lambda_2(\tau) d\tau \right] = R_1(\varphi) \quad (13)$$

(for self-evident reasons $t_e < t_1$)

In accordance with de.l'Hospital theorem, the radius φ determined by means of the equation

$$R_1'(\varphi) = 0 \quad (14)$$

gives the maximum value of $R(t_e)$ function

The radius φ leading to the maximum $E\{T\}$ value may be determined similarly. The life-time expected value is connected with the reliability function by means of formula (1) while $R(t)$ results from (13). The radius φ determined by means of the equation

$$\left[\int_0^{\infty} R_1(\varphi) d\varphi \right]' = 0 \quad (15)$$

gives the maximum value of $E\{T\}$

4. Summary

The presented methodics leads to the insulating systems of maximum possible reliability function $R(t_e)$ or of maximum expected value life-time $E\{T\}$, under imposed conditions. These conditions are as follows: the electrode geometry, the dielectrics of known dielectric susceptibilities ε_i and breakdown voltage characteristics $E_{bi}(t)$, working voltage U_{work} and the probability density function of the overvoltages $d(U_{ov})$.

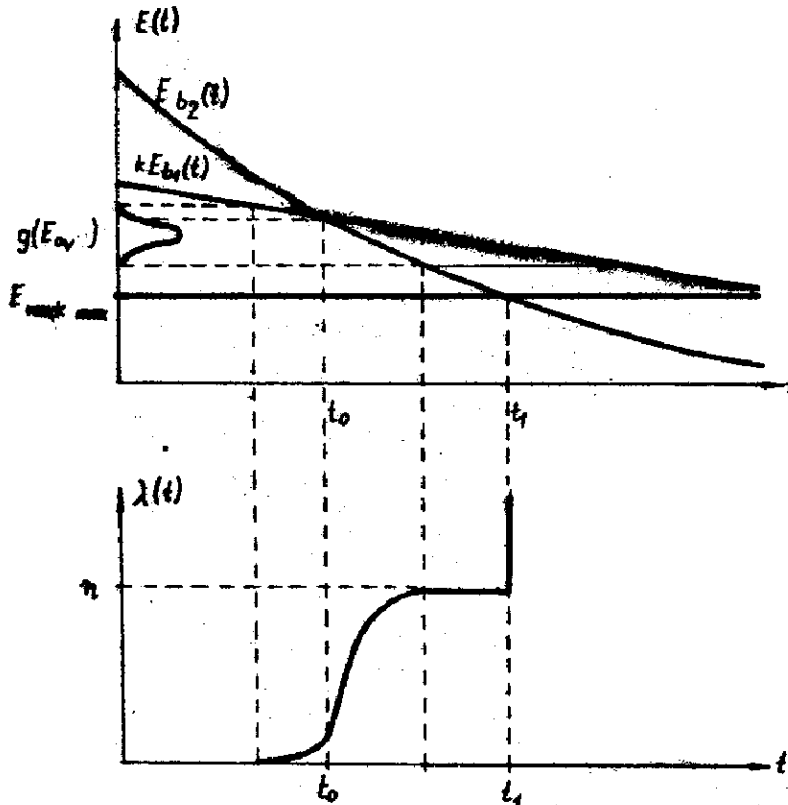

Fig.4. Determination of the hazard function for two-layer electric insulation influenced with working voltage and overvoltages

However, the above considerations are based on the simplified model of ageing phenomenon and ought to be developed. Particularly, the deterministic function $E_b(t)$ may be replaced with the stochastic one which takes into account the dependence of the ageing processes upon the various random variables.

R e f e r e n c e s

1. Karpiński J., Firkowicz S.: Zasady profilaktyki obiektów technicznych, Warszawa, 1981.
2. Nowakowski R., Spiridonow W.: Zbiór zadań z techniki wysokich napięć, Szczecin, 1961.
3. Układy izolacyjne urządzeń elektroenergetycznych, Warszawa 1978.
4. Haviland R.P.: Niezawodność urządzeń technicznych, Warszawa 1968.